

ALUMINIUM HOUSED POWER WIREWOUND RESISTORS **HS** SERIES

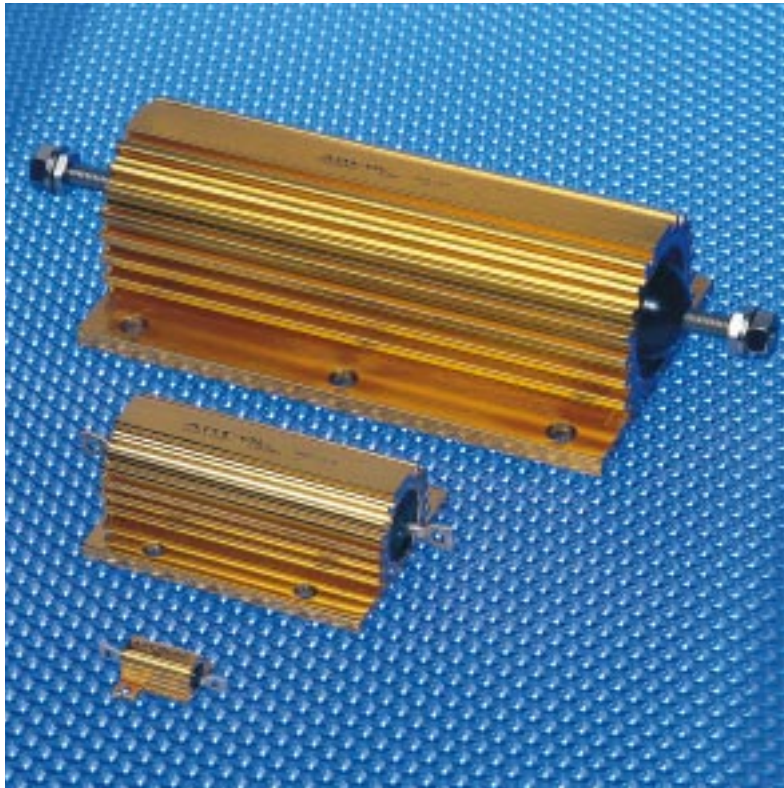

FEATURES

- DESIGNED FOR HEAT SINK MOUNTING
- LOW OHMIC VALUES DOWN TO R005
- SOLDER, CABLE, THREADED OR FAST-ON TERMINATIONS
- INDUCTIVE OR LOW INDUCTANCE
- MANUFACTURING APPROVED TO ISO 9001

The ARCOL HS style is a range of high quality, high stability aluminium housed power wirewound resistors designed for direct heat sink attachment. The resistive element is wound onto high thermal conductivity ceramic formers ground to a close tolerance finish ensuring maximum contact for rapid heat transfer. This element is encapsulated in the aluminium housing by a transfer moulding process which ensures a good humidity seal and a permanent compression fit. The encapsulant is a high temperature moulding compound and the special ARCOL mould tool design ensures accurate concentricity of the resistive element inside the housing giving a high level of voltage protection. Our engineers have 30 years experience in the design and manufacture of this style of resistor and during this period we have produced many different HS types to meet customers special requirements. If you need a special design for your application, be it high voltage, short term overload, special mounting or terminations then please contact us for advice.

CHARACTERISTICS

Tolerance	Standard J ($\pm 5\%$) and K ($\pm 10\%$). Also available F ($\pm 1\%$), G ($\pm 2\%$) and H ($\pm 3\%$).
Tolerance for low Ω values	Typically $\geq R05 \pm 5\% \leq R047 \pm 10\%$.
Temperature Coefficients typical values	< 1K 100ppm Std. > 1K 25ppm Std. For lower TCR's please contact Arcol.
Insulation resistance (Dry)	10,000 M Ω minimum.
Power dissipation @ high ambient temperatures	Dissipation derates linearly to zero at 200 °C.
Ohmic values	From R005 to 100K depending on wattage style.
Low inductive (NHS)	Specify by adding N before HS code e.g. NHS50.
NHS ohmic range	Divide standard HS maximum value by 4.
NHS working volts	Divide standard HS maximum working volts by 1.414.
Internal resistance	Available on request.
Core	Ceramic-steatite or alumina depending on size.
Element	Copper nickel alloy or nickel chrome alloy.
End caps	Nickel iron or stainless steel.
Encapsulant	High temperature moulding compound.
Housing	Anodised aluminium.
Terminals	HS10 to HS150: silver plated steel cored copper HS200 to HS300: Brass, stainless steel or copper clad steel.

ORDERING SYSTEM

N	H	S	2	5	2	R	2	J
LOW INDUCTION WINDING	SERIES		WATTS (MAX) HEAT SINK MOUNTED		NOMINAL VALUE (Ω)		TOLERANCE	
TOLERANCE CODE								
F = $\pm 1\%$			J = $\pm 5\%$			K = $\pm 10\%$		

ARCOL will be pleased to advise and to provide further information on the following subjects:

- HS resistors for pulse applications
- Maximum overload
- Inductance values
- Low ohmic values
- Special terminations
- Alternative aluminium housing designs and mountings
- Voltage applications

TEMPERATURE RISE & POWER DISSIPATION

Surface Temperature of resistor related to power dissipation. The resistor is standard heat sink mounted using a proprietary heat sink compound.

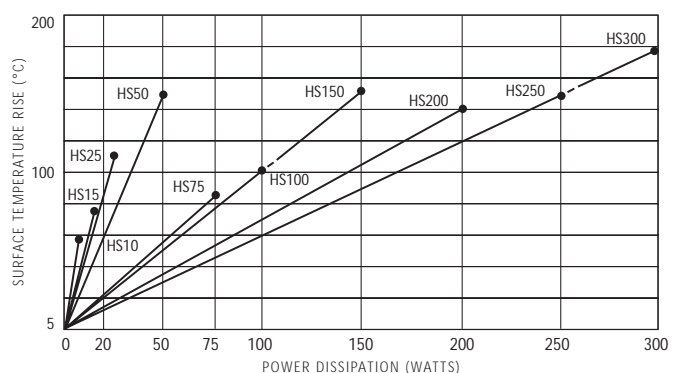

ALUMINIUM HOUSED POWER WIREWOUND RESISTORS **HS** SERIES

HEAT DISSIPATION AND MAXIMUM OVERLOAD

HEAT DISSIPATION Whilst the use of proprietary heat sinks with lower thermal resistance is acceptable, uprating is not recommended. For maximum heat transfer it is recommended that a heat sink compound be applied between the resistor base and heat sink/chassis mounting surface. It is essential that the maximum hot spot

temperature of 200°C is not exceeded and therefore the resistor must be mounted on a heat sink of correct thermal resistance for the power being dissipated.

MAXIMUM OVERLOAD Please consult the factory for assistance concerning your particular overload application.

ELECTRICAL SPECIFICATIONS

ARCOL TYPE	STYLE MIL-R 18546	POWER RATING ON STANDARD HEAT SINK @ 25°C	WATTS @ 25°C WITHOUT HEAT SINK	RESISTANCE RANGE OHMS	LIMITING ELEMENT VOLTAGE DC/AC RMS	VOLTAGE PROOF AC PEAK	VOLTAGE PROOF AC RMS	APPROX WEIGHT GMS	TYPICAL SURFACE TEMPERATURE RISE °C/W STANDARD HEAT SINK MOUNTED	STANDARD HEAT SINK (ALUMINIUM)	
										AREA CM ²	THICKNESS (MM)
HS10	RE60	10	5.5	R005-10K	160	1400	1000	4	5.8	415	1
HS15	RE65	15	8	R005-10K	265	1400	1000	7	5.1	415	1
HS25	RE70	25	12.5	R005-36K	550	3500	2500	14	4.2	535	1
HS50	RE75	50	20	R01-86K	1250	3500	2500	32	3.0	535	1
HS75		75	45	R01-50K	1400	6363	4500	85	1.1	995	3
HS100		100	50	R01-70K	1900	6363	4500	115	1.0	995	3
HS150		150	55	R01-100K	2500	6363	4500	175	1.0	995	3
HS200		200	50	R01-50K	1900	7070	5000	475	0.7	3750	3
HS250		250	60	R01-50K	2200	7070	5000	600	0.6	4765	3
HS300		300	75	R01-68K	2500	7070	5000	700	0.6	5780	3

DIMENSIONS

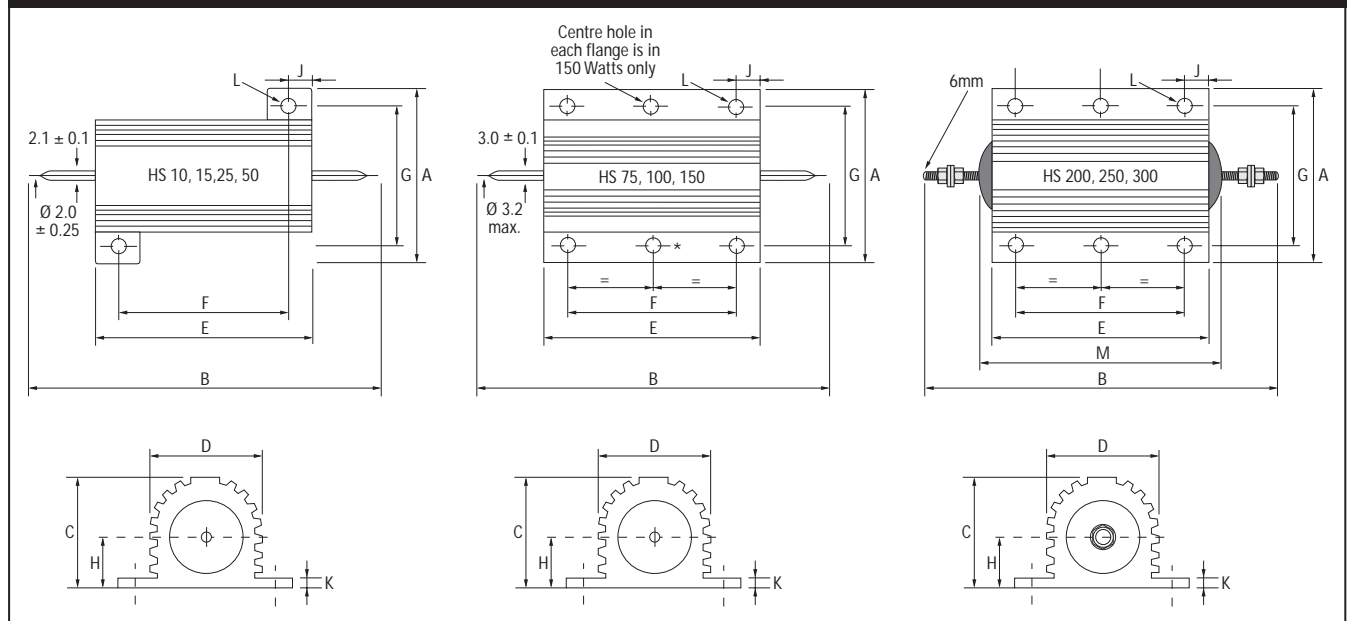

ARCOL TYPE	DIMENSIONS (MM)											
	A MAX	B MAX	C MAX	D MAX	E MAX	F ± 0.3	G ± 0.3	H MAX	J MAX	K MAX	L ± 0.25*	M MAX
HS10	16.5	30.0	8.8	8.5	15.9	11.3	12.4	4.5	2.4	1.8	2.4	---
HS15	21.0	36.5	11.0	11.2	19.9	14.3	15.9	5.5	2.8	1.8	2.4	---
HS25	28.0	51.0	14.6	14.0	27.3	18.3	19.8	7.3	4.7	2.6	3.2	---
HS50	29.7	72.5	14.8	14.2	49.1	39.7	21.4	8.5	5.2	2.6	3.2	---
HS75	47.5	72.0	24.1	27.3	48.7	29.0	37.0	11.8	10.4	3.7	4.4	---
HS100	47.5	88.0	24.1	27.3	65.2	35.0	37.0	11.8	15.4	3.7	4.4	---
HS150	47.5	121.0	24.1	27.3	97.7	58.0	37.0	11.8	20.4	3.7	4.4	---
HS200	72.5	145.7	41.8	45.5	89.7	70.0	57.2	20.5	10.4	5.5	5.1	103.4
HS250	72.5	167.0	41.8	45.5	108.7	89.0	57.2	20.5	10.4	5.5	5.1	122.4
HS300	72.5	184.4	41.8	45.5	127.7	104.0	59.0	20.5	12.4	5.5	6.6	141.4

*200 - 300 Watts is ± 0.45

ARCOL UK LTD

THREEMILESTONE INDUSTRIAL ESTATE, TRURO, CORNWALL, TR4 9LG, ENGLAND.

Tel +44 (0)1872 277431 Fax +44 (0)1872 222002

http://www.arcol.co.uk E-mail sales@arcol.co.uk



CERTIFICATE NUMBER FM31218